

2

1

TOP VIEW

ISOMETRIC VIEW

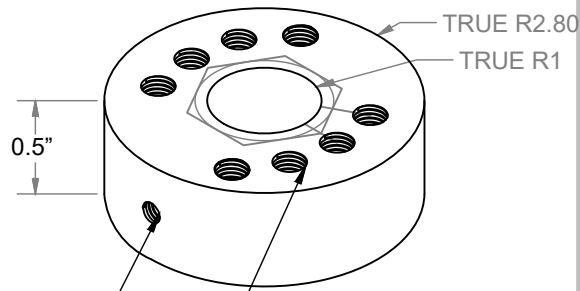
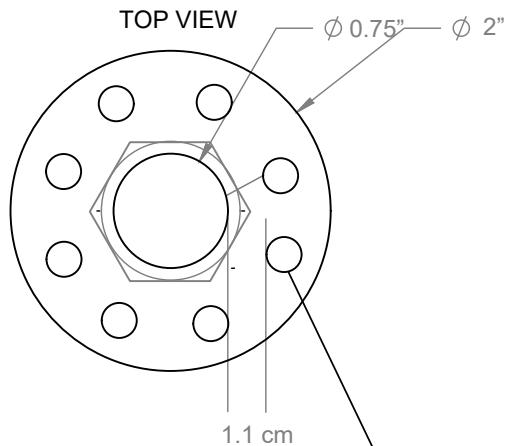

#8-32 Set screw to center

1/4-28 thread on one side, 10-32 thread on other.

note: thru holes are threaded for first 0.2", end in FLAT bottom Do for each side. Thru hole between two threaded ends is 0.062" diam

All dimensions are in cm unless otherwise noted as inches.

B

B

A

A

2

1

TITLE:

OlfacDisk

SIZE

MW Lab

RV

SCALE: 1:1 WEIGHT:

SHEET 1 OF 1